

PROPEX 10L WATER STORAGE HEATER



Propex Heating and Leisure are pleased to present a new water heater designed especially for the Caravan and Motorhome market. A choice of mounting options and variable temperature settings ensures the right choice for your needs.

The increase in quality and availability of site 'hook ups' means the need to have multi-fuelled water heaters is no longer a necessity for a lot of campers. So pull up, hook up and switch on to ensure lashings of hot water will always be available with the mains powered water storage heater.



Temperature Gauge



Easy Intuitive Controls



Multiple Safety Devices

QUICK
EFFICIENT
WATER HEATER
Specifically engineered
for touring vehicles
caravans and motor homes



**ENGINEERED FOR
COMFORT & RELIABILITY**



Special Features:

- € The inner tank is made of super steel plate with wet enamel coating – very tough, very strong, resistant to corrosion and water scale, giving a long life.
- € Ultra-thick, non-CFC polyurethane foam to prevent heat loss and reduce energy costs.
- € Super compact design, novel and luxurious appearance, easy to mount in a bedbox, locker or under seat storage area.
- € Temperature meter and adjustment knob.
- € Multiple protection devices against over temperature, over pressure and electricity leakage.
- € Choice of pipe connections and comes fitted with 3-pin plug for fast and easy installation.

Technical:

Rated Voltage:	220v
Rated Power:	900W
Rated Frequency:	50HZ / 60HZ
Rated Current:	4.1A
Rated Pressure:	0.8MPa (7psi)
Rated Water Temperature:	75°C
Fitted Socket:	250V, 16A
Heating Efficiency:	>90%
Warranty:	5 year tank guarantee

Supplied mounting bracket allows secure installation to wall and floor. Supplied water hose connectors give options of 12mm push fit female fitting or adaptor to 12mm barbed hose connector.

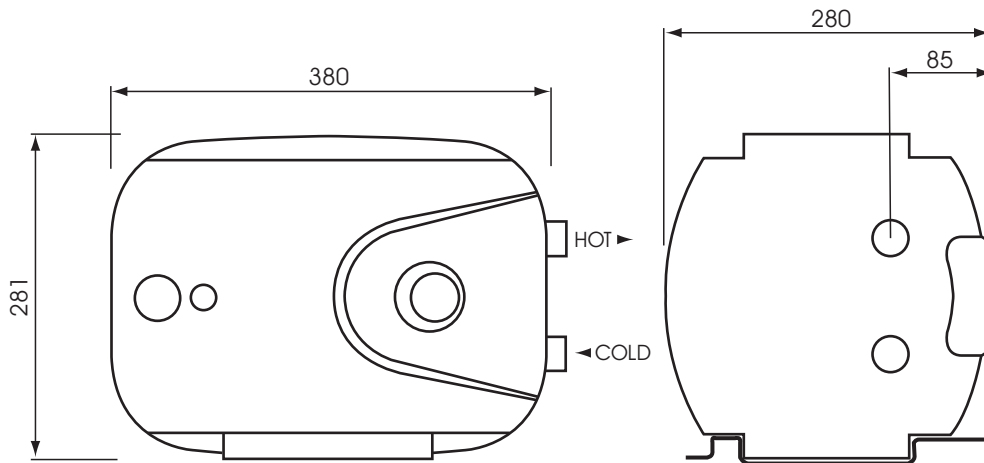

TECHNICAL SPECIFICATIONS

Model No.	Rated Volume	Product Size (mm)	Carton Size (mm)	NW (kg)	GW (kg)
DSZF15-LJ/10C2	10 litre	378 x 276 x 280	420 x 300 x 335	4.8	6.5



ENGINEERED FOR
COMFORT & RELIABILITY

Propex Heating and Leisure Limited

Unit 5, Second Avenue, Millbrook, Southampton SO15 0LP

Tel: 023 8052 8555 Fax: 023 8052 8800 Email: sales@propexheatsource.co.uk

