



Heatsource
HS1800
Heater



Vehicle
Installation
&
Operation Instructions

ENGINEERED FOR
COMFORT & RELIABILITY

SAFETY WARNINGS & GENERAL INFORMATION

The heater must be installed by a corgi registered person or inspected by a corgi registered person in accordance with the relevant regulatory and safety requirements.

Heater installations must comply with the current British standards for Motorhomes / Caravans and BS5482 Part 3 for Boats.

The Heatsource HS1800 heater is not suitable for installation on the outside of the vehicle.

The heater must not be operated when refueling or when the vehicle is in a confined space, such as a garage.

The exhaust gas outlet must not be fitted on the entry door nor in any position where combustion products may enter the interior.

The Heatsource HS1800 heater is designed to operate on Propane gas 37mbar or Butane at 28 or 30mbar. The HS1800 may also be used on 30mbar propane but the heat output will be reduced. A 50mbar Propane model is also available. Under no circumstances should an adjustable regulator be used.

Do not allow materials to come in to direct contact with the heater. Under no circumstances must the intake grill be covered or obstructed at any time.

The Heatsource HS1800 heater has been tested and passed the relevant sections of the following standards:

EN5008-1 EN55014-1 EN60945 EN50082-1 EN50014-2 EN50165
ISO7637-1 ISO7637-2 EN624/2000 EN298

A data label is situated adjacent to the gas inlet.

The gas supply line should be checked regularly for damage or leaks and tested under pressure with a proprietary leak tester. **NEVER TEST FOR GAS LEAKS WITH NAKED FLAME.** If a gas leak is detected or smelt, turn off gas at the bottle immediately and ventilate the area. Contact a corgi registered installer to rectify the problem.

The heater is suitable for use while the vehicle is in motion subject to gas regulations.

Heatsource is suitable for boats when supplied with the correct marine installation kit.

IMPORTANT: Do not direct the combustion products outlet terminal towards the combustion products inlet terminal.

VEHICLE INSTALLATION

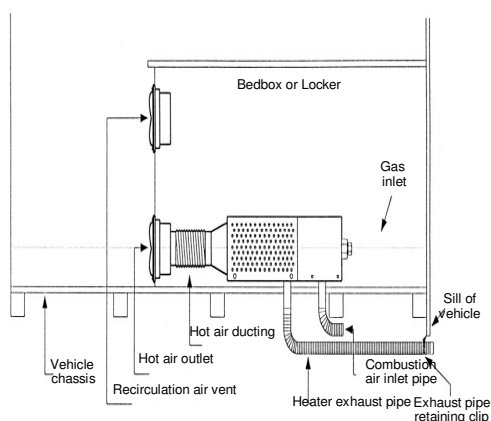

FITTING THE HEATER

Find a suitable location, usually in a bedbox, locker or base of a cupboard. The Heatsource HS1800 should be fitted in an area allowing a minimum distance of 25mm from adjacent walls, ceiling or shelves from the main body of the heater. Check that there are no chassis members underneath the location of the exhaust and combustion air spigots.

Using the template provided, drill a 3mm pilot hole through the exhaust and combustion air spigot centres. Examine underneath the vehicle to check that there is adequate clearance for a 30mm hole saw. Cut away any carpet or matting around the exhaust and open out the holes to 30mm.

Loosen the 4 x M4 screws on the base of the heater and slot the mounting brackets into position, then re-tighten the screws. Mount the heater in position and mark the 4 mounting holes on the floor of the vehicle for screwing the heater down. Remove the heater and drill 4 x 3.5mm holes in the marked positions, then screw the heater in place with the 3/4 x N0.8 self tapping screws provided.

Find suitable locations for the hot air outlet and re-circulation air inlet vent and drill a 5mm pilot hole through each centre. Using a 95mm hole saw, drill out the holes and fix the vents in position using the black 1/2 x No.8 counter sunk self tapping screws provided.

Fix the 60mm reducer (push fit) into the back of the hot air outlet. Cut the 60mm thermoplastic ducting to length and fix to the heater and the outlet using the 50-70mm hose clips provided.

NOTE: There is no reducing spigot provided for the air inlet vent, as it is not necessary to put ducting on it.

A 1 metre length of 22mm flexible stainless steel tubing with a special end cap is supplied for ducting the products of combustion away to the edge of the vehicle. The tube may be cut to length and fixed to the heater using the hose clip provided.

A "P" clip is provided for fixing the end of the pipe to the underside of the vehicle with the end cap slightly protruding under the sill or bumper and pointing towards the rear of the vehicle. If it not possible to exhaust the heater to the sill then it is permissible to terminate the flue underneath the vehicle but if it exists in an under-floor box section then at least one side of it must be open to the atmosphere.

The maximum overall length of the flue and inlet pipe combined can be up to 2 metres if required. However, the flue pipe should never be shorter than the combustion air inlet pipe.

A 300mm length of combustion air pipe is provided, which is also fitted with an end cap. This should be attached to the heater with the hose clip provided and pointed in the same direction as the flue pipe.

Note: The combustion air pipe can be terminated underneath the vehicle making sure the end of it is at least 0.5 metres away from the end of the exhaust. Take care to ensure that both pipes have a slight downward slope to prevent any possibility of water traps. Make sure that the flue is not terminated in an under-floor box section.

GAS CONNECTION

The heater uses an 8mm (5/16") gas connection which also incorporates a test point .

The gas supply should be connected with copper gas pipe with an isolating valve and all connections made with brass compression fittings, fitted with copper olives.

When the gas line is complete all joints should be tested for leaks using leak detection solution - **NEVER WITH A NAKED FLAME.**

Gas pressure should be verified at the test point using a low pressure gauge or "U" tube, any tests or connections should only be undertaken by a Corgi registered person.

NOTE. Net Heat Input: 1.8kw

WIRING INSTRUCTIONS

Stat Ref	Cable Colour.
+	Red
-	Black
On	Orange
LED	White
Vent	Green

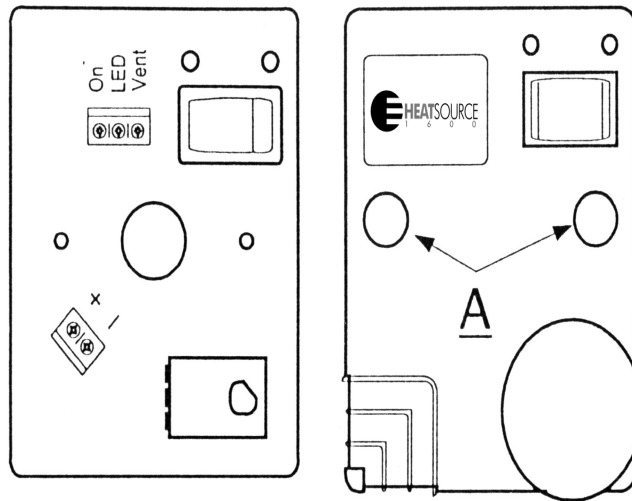

The Heatsource HS1800 heater is supplied with 2 wiring looms, a 2 core (red and black) and a 5 core (red, black, orange, white and green), both are fitted with terminals and housings to plug into the main PCB inside the heater and are supplied already connected.

Find a suitable location for the thermostat between waist and shoulder height. Make sure that it is not mounted in an area with poor air circulation or in an area with above average heat, such as above a cooker, refrigerator or in direct sunlight.

When you have chosen the location, drill a pilot hole in the area you expect to retrieve the 5 core cable. If the clearance is OK, open the pilot hole out to 10mm.

Run the 5 core cable from the heater to the thermostat location and remove approximately 60mm of the outer insulation.

Remove the thermostat knob by gently prizing it off and undo screws "A" to remove the cover.

Fix the backplate with the PCB to the wall making sure the 5 core cable is pulled through the hole in the centre.

Connect the cable to the terminal blocks as in the diagram and refit the lid.

Replace the thermostat knob and push the finishing caps into the lid to cover the screw heads

Run the 2 core cable to a convenient supply (usually at the battery) and connect using the fuse holder supplied.

Insert the 5 amp fuse and test.

OPERATION

Before use: Pay particular attention to the exhaust and combustion air inlets to check that neither have been blocked or damaged. Ensure that any snow or slush is clear from the part of the vehicle where the heater exhaust is mounted.

Check the gas supply is turned on and that the battery voltage is correct (see specifications).

Rotate the thermostat dial fully anti-clockwise and push the 3 position switch to the left. The red power light should illuminate.

Rotate the thermostat dial until the green light illuminates. After 3 seconds the heater motor will start and ignition should occur after a 30 second pre-purge cycle.

Find the desired temperature setting by adjusting the dial on the thermostat. The heater will then cycle on and off to maintain that temperature.

When the set temperature is reached the green light will go out and the heater will start its post purge cycle. When the motor switches off, the red power light will dim indicating that the heater is on standby.

If the 3 position switch is depressed on the right, the green LED will illuminate and the fan will blow cold air continuously.

Sequence of operation:

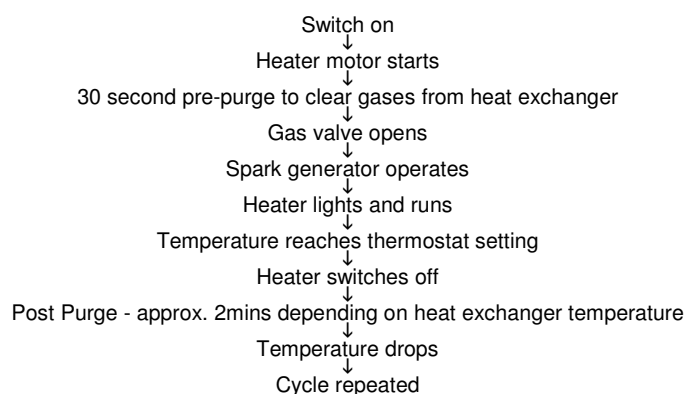

MAINTENANCE

The installation should be inspected annually by a corgi registered person and any servicing and cleaning identified carried out.

The heater should not be left for long periods without use. It is advisable to run the unit for short periods throughout the summer.

The inlet grill on the heater should be inspected periodically for excess foreign matter and cleaned if necessary.

FAULT FINDING

The Heatsource HS1800 is equipped with an electronic diagnostic system for fault finding. In the Event of a failure the red light on the thermostat will flash a certain amount of times, then pause and it will repeat this until switched off.

Manual Overheat Cut-Out. The HS1800 is equipped with a manually resetting thermal cut-out in addition to the electronic cut-out. This is designed to disengage the gas solenoid valve if the electronic cut-out fails and can operate if the heater is switched off at the battery isolating switch without allowing it to purge. It can be found by removing the inlet grill and following the two purple wires from the main PCB. Press the red button, the fault code would be 2 flashes.

FAULT FINDING TABLE

No. of Flashes	Symptoms	Possible Causes
1	Failed to Ignite	No gas left in bottle Bottle or gas tap turned off Incorrect gas pressure Igniter in heater failed
2	Flame Sensing	Run out of gas whilst operating Gas switched off Ingestion of gas through combustion air intake Low gas pressure
3	Low Voltage	Battery voltage low Bad connection in supply Cut out 12V Model = 10V - 24V Model = 18V
5	Combustion air flow low	Blocked / partially blocked exhaust / combustion air inlet Water trapped in exhaust pipe Damaged / crushed exhaust Fan motor running slow
6	Gas Solenoid Valve	Faulty valve in heater
8	High Voltage	Voltage too high 12V model = 15.5V - 24V Model = 30V
9	Heat exchange temperature high	Blocked inlet grill or obstructed hot air outlet Fan speed low Faulty thermistor

PROPEX



PROPEX HEATSOURCE LTD
Unit 5, Second Avenue Business Park,
Millbrook, Southampton. SO15 0LP

Tel: 023 8052 8555
Fax: 023 8052 8800
Website: www.propexheatsource.co.uk
Email: info@propexheatsource.co.uk