

All gas appliances must be installed and/or commissioned by corgi registered persons.

PROPEX



PROPEX HEATSOURCE LTD
Unit 5, Second Avenue Business Park,
Millbrook, Southampton. SO15 0LP

Tel: 023 8052 8555
Fax: 023 8052 8800

Website: www.propexheatsource.co.uk
Email: info@propexheatsource.co.uk

702 issue D



Malaga II / IIE
Storage Water
Heater

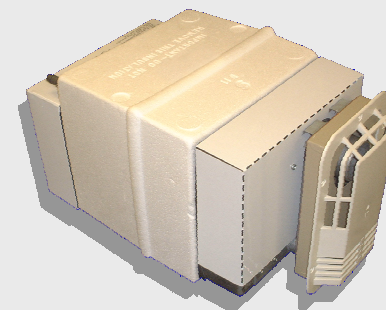

Installation
&
Operation Instructions

ENGINEERED FOR
COMFORT & RELIABILITY

USER INSTRUCTIONS

- The Propex Malaga II is for use on L.P.Gas only
- The Propex Malaga IIE is for use on both L.P.Gas and mains electricity

On initial operation or when the system has been drained, refill the system with water and flush out by turning on each hot tap until a steady flow of water is obtained. If a water filter is fitted it should be changed at the recommended intervals.

Check that the Gas and Electricity supplies are turned on.

OPERATION

Gas - Switch on the heater. Initially the red light will come on followed by the green light which will stay lit as long as the burner is alight. If the gas does not light and the red light comes back on - switch off - wait 10 seconds and switch on again. Several attempts may initially be required for purging.

Note: When the water has reached the preset temperature no lights will show. As the water cools or is drawn off the heater will automatically relight and the green light will come on until the water has again reached temperature.

If at any time the light comes on indicating a fault condition, wait 3 minutes before attempting to relight. If the fault persists, check that:

- (i) The gas supply has not run out
- (ii) The battery is fully charged

Electricity - The Malaga IIE has a 230v electric element which can be used independently or in addition to the gas burner.

Note: A 12v D.C. supply must be connected at all times.

Water - This appliance must not be connected directly to the Mains Water Supply.

Battery - The heater is designed to operate on a 12v D.C. supply. Should the supply drop to 9 volts the heater will shut off for safety. Turn off the heater and recharge the battery before reusing the heater.

Winter operation - When using the heater in Winter ensure that the flue is not blocked by snow or fallen leaves etc.

When not in use the heater should be drained as follows:

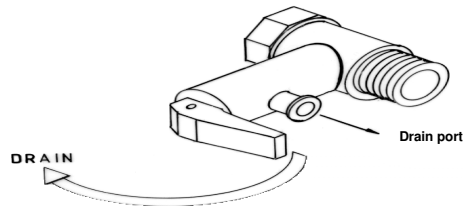

230VAC WIRING DIAGRAM

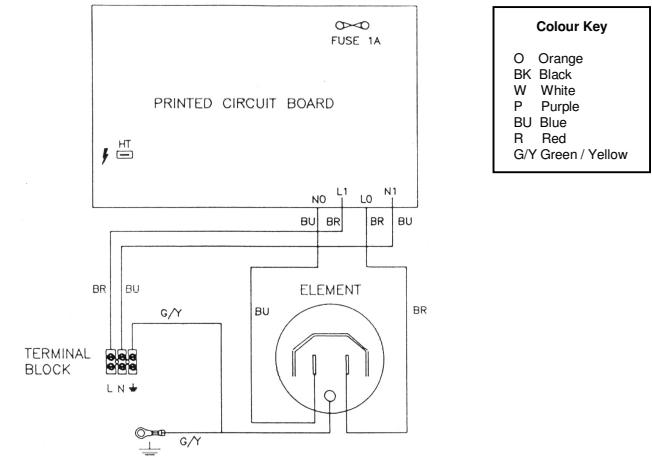

12VDC WIRING DIAGRAM

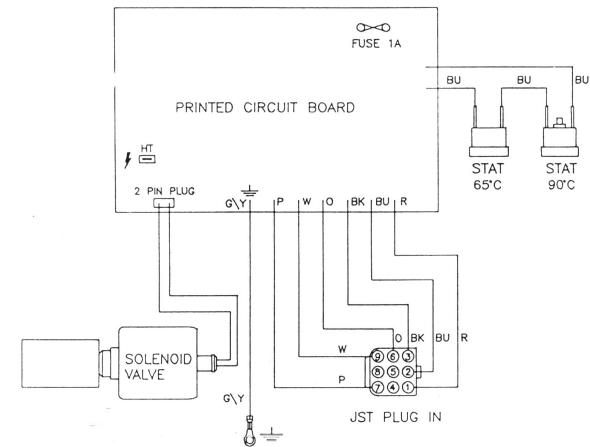

SWITCH HARNESS

12v CONNECTION
Blue = + (Positive)
White = - (Negative)

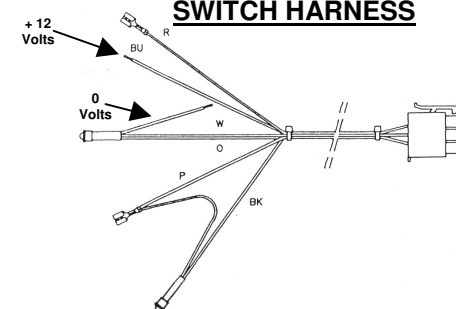

CONNECTING THE WATER HEATER

1 - WATER

Use half reinforced, food quality, opaque or similar pipework only. The "Hot" and "Cold" connections are clearly marked and it is important that they are connected correctly. If the plastic inlet connection supplied with the heater is removed it is important that only a plastic replacement is used. The outlet connection at the top of the tank must not be removed as this houses an additional internal tube which provides the air space for expansion inside the tank. The water pressure must not exceed 1.3 Bar.

DO NOT CONNECT THIS APPLIANCE TO THE A MAINS WATER SUPPLY

Drain / Pressure Relief Valve - Drill the appropriate sized hole in the floor close to the heater. Fit a piece of hose from the drain through the floor and seal the floor with silicon rubber or similar material.

Water Systems - The heater will operate satisfactorily on either system where the pump is controlled by a tap, microswitches or a pressure switch.

2 - GAS

The gas connection is 8mm and suitable compression fitting is required. An isolation tap should be fitted near to the heater and any unsupported pipework secured. It is recommended that a gas drop hole is positioned near to the heater. All gas connections should be carried out by a corgi registered person.

3 - ELECTRICITY

Fit the wall switch in the chosen position and route the wiring to the heater. Connect the 12v supply to the switch and plug into the heater.

Note: Check that the polarity is correct.

Malaga IIE only - The appliance should be connected to a 230v AC - 5 amp fused spur.

Note: This appliance must be earthed.

FAULT FINDING - CHECK LIST

1 - Check that the following supplies of gas, water and electricity are available

Gas	Butane - 28/30 mbar or Propane 37mbar
Water	Turn on a hot tap and check for a steady supply of water
Battery / Transformer	12V d.c. supply
	Colour code - Blue 12v - White OV
Malaga IIE only	Mains electricity 230v - A.C. 50Hz (fused 5A)

2 - Heater not working - No L.E.D. lit

- (i) Disconnect 9 way plug from heater and remove controls cover.
- (ii) Check for continuity between contacts 1 & 2 on 9 way socket
 - If no continuity check:
 - a) Manual reset button.
 - b) Fuse.
 - c) Wiring Contacts.
 - d) Continuity across thermostats.

3 - Replace 9 way plug and switch heater on

- (i) Check for 12v at 1
- (ii) Check for supply at solenoid 10 - 12V
 - If yes change solenoid, if no change PCB

4 - No spark at burner

- (i) Check ignition lead, electrode and burner
- (ii) If items above correct - change PCB

5 - Mains element - Malaga IIE only

- (i) Check continuity terminal block to printed circuit board
- (ii) Check continuity printed circuit board to element - if no replace PCB
- (iii) Check element resistance (70 OHMS)

Note: There is an element overheat cut-out switch in the element base

TECHNICAL DATA

Dimensions	Height - 250mm
	Width - 285mm
	Depth - 520mm
Weight empty	9.3kg
Inward protrusion from wall	480mm

Clearances required for installation and servicing, as seen from the inside.

Left Hand Side	240mm
Right Hand Side	100mm
Top	5mm

Water	Maximum Supply Pressure	1.3 BAR
	Pressure Relief Valve Setting	3.0 BAR
	Working Pressure	2.0 BAR
Gas	Heat Input	1.15kw / 80g/h
	Pressure Setting	Propane 37 mbar
	CAT I3+	Butane 28 mbar
	Injector	BRAY 960 / 40
	Gas Connection	8mm O.D.
Electricity	Malaga II	12v D.C.
	Malaga IIE	12v D.C.
		230v 50hz 5a fuse

ELECTRODE SETTING

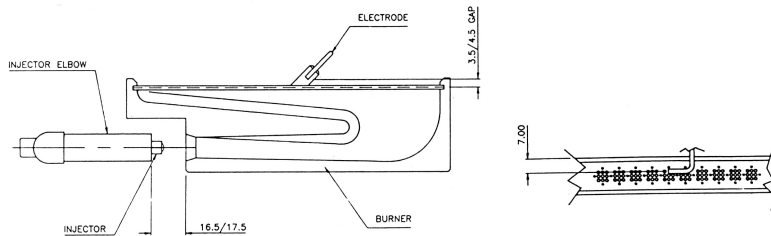

INSTALLATION

Installation and servicing of this appliance must only be carried out by corgi registered persons.

Prior to installation check that the gas supply pressures & type are compatible. (see data plate on appliance)

This appliance must be installed in accordance with the current regulations. In the United Kingdom the installation must be in accordance with BS6501 Pt 1 1978, BS5482 Pts 1 & 2 1977 and BS5440 Pt 2 1990.

The Malaga II Water Heater is designed to be floor mounted and flues through a vertical section on external wall. Normally the heater would be fitted in a bedbox or locker. Structural sections within the vehicle should not be damaged (see technical information for details).

Flue - Using masking tape, fix the template to the inside of the vehicle and drill a pilot hole at position X. Remove the template and tape it to the outside of the vehicle ensuring that the template is square and that the centre lines up with the hole drilled from the inside.

Drill a 10mm hole at positions A and, using a jigsaw, cut out the hole. The hole in the wall must be battened to secure the inner and outer skins.

Note: When battening the finished hole must be 240mm x 135mm. Run a bead of silicon rubber or similar seal around the edge of the ear side of the flue cover, position into cut-out in wall and secure with screws.

Water Heater - Remove the floor covering (e.g. carpet etc) from the area where the water heater will stand - 450mm inward from the wall and 320mm wide. Draw a line on the floor from the centre of the flue 600mm into the vehicle.

Slide through the flue seals until the stop position is reached. Make sure both flue and air intake pass through the lip seals.

Line up the marker on the rear of the heater with the line on the floor and screw the heater to the floor.

